



**FITTING INSTRUCTIONS FOR LP0316 LICENCE PLATE BRACKET  
DUCATI MONSTER 950 (PLUS) 2021-**



**This kit contains the items pictured and labelled over page.**

**Some parts may be shown for clarity of instructions only.**

**Do not proceed until you are sure all parts are present.**

**Please read all instructions before proceeding.**

**IF IN ANY DOUBT WHEN FITTING OUR PRODUCTS, CONSULT ONE OF OUR DEALERS  
OR HAVE FITTED BY A QUALIFIED TECHNICIAN.**

Please note that the way the kit is packed does not necessarily represent the way of mounting to the bike.

In the event of rubber washers being used to hold components onto bolts, these rubber washers can be thrown away.

**DIGITAL COPIES OF THESE INSTRUCTIONS ARE AVAILABLE FROM**

**[WWW.RG-RACING.COM](http://WWW.RG-RACING.COM)**

R&G

Unit 1, Shelley's Lane, East Worldham, Alton, Hampshire, GU34 3AQ

Tel: +44 (0)1420 89007 Fax: +44 (0)1420 87301 [www.rg-racing.com](http://www.rg-racing.com) Email: [info@rg-racing.com](mailto:info@rg-racing.com)



- Set of metric Allen keys to include 3, 4, 5 & 6mm
- 6 & 8mm spanner or socket.
- Small flat head screwdriver.

**GENERAL TORQUE SETTINGS**

M4 BOLT = 8Nm  
 M5 BOLT = 12Nm  
 M6 BOLT = 15Nm  
 M8 BOLT = 20Nm  
 M10 BOLT = 40Nm  
 M12 BOLT = 40Nm

**LEGEND**

ITEM No.	DESCRIPTION	QTY
ITEM 1	TB0316 PART 1 - LICENSE PLATE BRACKET	1
ITEM 2	MP0253 - INDICATOR MOUNT LHS	1
ITEM 3	MP0254 - INDICATOR MOUNT RHS	1
ITEM 4	CON0014 - LICENCE PLATE ILLUMINATOR CONNECTOR	1
ITEM 5	CON0015 - INDICATOR CONNECTOR	2
ITEM 6	LA0002 - NUMBER PLATE LIGHT ASSEMBLY	1
ITEM 7	M5x0.8x10.0 mm COUNTER SUNK SCREWS	4
ITEM 8	M5x0.8 NYLOC NUTS	4
ITEM 9	M5x10mm WASHERS	4
ITEM 10	REFL 3 - REFLECTOR	1
ITEM 11	150mm LENGTH OF HEATSHRINK	3
ITEM 12	2.5mm x 100mm CABLE TIES	6
ITEM 13	IWC0002 - MINI INDICATOR WIRING COVERS	2
ITEM 14	CLIP 1 - SELF ADHEISIVE CABLE CLIPS	2
ITEM 15	I0071 - MINI INDICATOR ADAPTORS	4

R&G

Unit 1, Shelley's Lane, East Worldham, Alton, Hampshire, GU34 3AQ

Tel: +44 (0)1420 89007 Fax: +44 (0)1420 87301 [www.rg-racing.com](http://www.rg-racing.com) Email: [info@rg-racing.com](mailto:info@rg-racing.com)



**ASSEMBLY DIAGRAM**

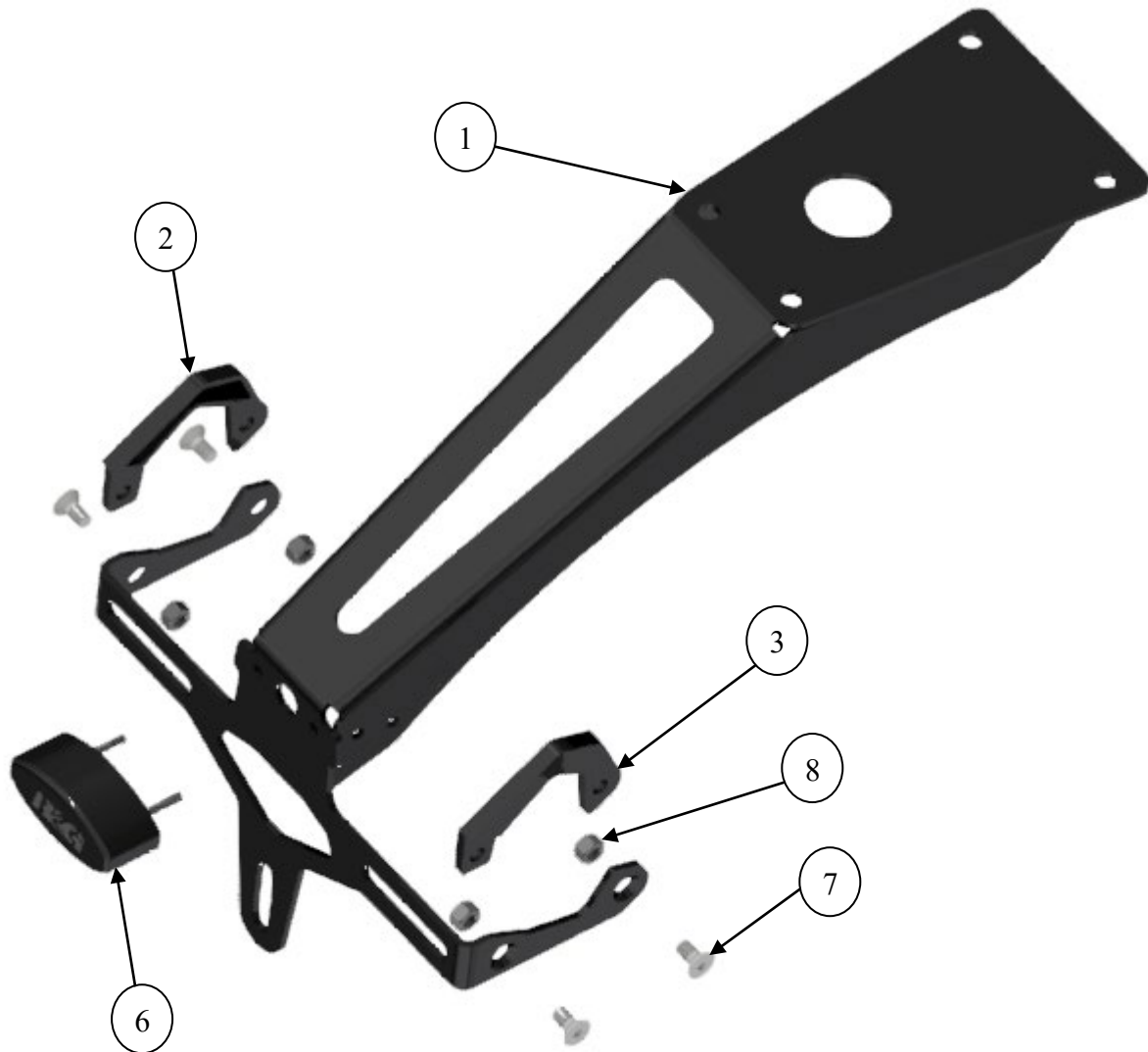



**FITTING PICTURES**

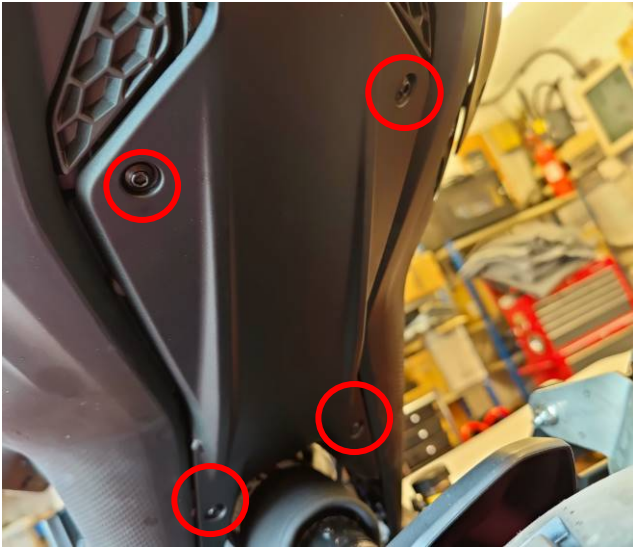

Picture 1



Picture 2



Picture 3



Picture 4

R&G

Unit 1, Shelley's Lane, East Worldham, Alton, Hampshire, GU34 3AQ

Tel: +44 (0)1420 89007 Fax: +44 (0)1420 87301 [www.rg-racing.com](http://www.rg-racing.com) Email: [info@rg-racing.com](mailto:info@rg-racing.com)



Picture 5



Picture 6



Picture 7



Picture 8

## **FITTING INSTRUCTIONS**

- Begin by removing the 4 bolts shown in **Picture 1** with a 4mm Allen Key.
- This allows you to remove the plastic cover plate, exposing the license plate bracket mounting screws and wiring.
- Remove the rubber cable tie and disconnect the 3 connectors shown in **Picture 2**.
- Remove the 4 bolts shown in **Picture 3** with a 5mm Allen key and remove the OEM license plate bracket.
- This leaves the 3 wires exposed as shown in **Picture 4**.
- If re-using the OEM indicators, sandwich the rubber part of the indicators between the R&G license plate bracket and the indicator mounts. This can then be secured with the M5 fasteners

R&G

Unit 1, Shelley's Lane, East Worldham, Alton, Hampshire, GU34 3AQ

Tel: +44 (0)1420 89007 Fax: +44 (0)1420 87301 [www.rg-racing.com](http://www.rg-racing.com) Email: [info@rg-racing.com](mailto:info@rg-racing.com)



provided. Note that the rubber may need to be compressed slightly to allow the screws to pass through the holes.

- If using R&G mini or other aftermarket indicators, assemble the mounting plates as above, without the indicators in place. Then use the indicator adaptors provided to secure the indicators.
- Secure the license plate illuminator light in position as shown in **Picture 6**.
- Fit the R&G tail tidy to the bike, securing with the same 4 bolts which removed the OEM license plate bracket. Make sure to pass the wires connected to the bike, through the large hole at the centre of the bracket.
- Re-connect the indicators and illuminator, ensuring that the left and right-side indicators are connected correctly. Note that the provided connectors may need to be used to connect bullet connectors to the OEM clip connectors.
- The indicator and illuminator wires can be tidied up using the cable ties provided and the small cable tie holes in the bracket.
- The Plastic cover piece shown in **Picture 7** can then be re-fitted using the 4 screws removed at the start of the process. This cover piece can also be used to hide the wiring and connectors.
- The tail tidy is then ready to attach your license plate as shown in **Picture 8**.

**IMPORTANT: IF FITTING A FULL-SIZE LICENCE PLATE AND PLACING IT FAR DOWN ON THE LICENCE PLATE HANGER, THERE IS A SMALL CHANCE OF THE LICENCE PLATE HITTING THE BACK WHEEL UNDER HEAVY LOAD AND OVER LARGE BUMPS IN THE ROAD. IT IS YOUR RESPONSIBILITY TO CHECK FOR THIS POSSIBILITY AND TAKE AVOIDING ACTION. FAILURE TO CHECK THIS COULD RESULT IN SERIOUS INJURY.**

ISSUE 1 - 19/08/2021 - (WW)

#### CONSUMER NOTICE

The catalogue description and any exhibition of samples are only broad indications of the Products and R&G may make design changes which do not diminish their performance or visual appeal and supplying them in such state shall conform to the order. The Buyer acknowledges no representation or warranty (other than as to title) has been given or will apply to the Products other than those in R&G's order or confirmation and the Buyer confirms it has chosen the Products as being of merchantable quality and suitable for its particular purposes. Where R&G fits the Products or undertakes other services it shall exercise reasonable skill and care and rectify any fault free of charge unless the workmanship has been disturbed. The Buyer is responsible for ensuring that the warranty on the motorcycle is not affected by the fitting of the Products. On return of any defective Products R&G shall at its option either supply a replacement or refund the purchase money but shall not be liable if the Products have been modified or used or maintained otherwise than in accordance with R&G's or manufacturer's instructions and good engineering practice or if the defect arises from accident or neglect. Other than identified above and subject to R&G not limiting its liability for causing death and personal injury, it shall not be liable for indirect or consequential loss and otherwise its liability shall be limited to the amounts paid by the Buyer for the Products or the fitting or service concerned. These terms do not affect the Buyer's statutory rights.

#### R&G RACING RETURNS POLICY (NON-FAULTY GOODS)

Returns must be pre-authorized (if not pre-authorized the return will be rejected). Goods may only be returned direct to us if they were purchased direct from us (customer must prove if necessary). Otherwise to be returned to original vendor. Goods must be in re-sellable condition, in the opinion of R&G Racing. All returns are subject to a 25% restocking and handling fee (25% of the gross value exc. P&P – at the prevailing price at time of purchase). The customer must pay any and all carriage charges. No returns of discontinued products, unless within 14 days of purchase. This policy does not affect your statutory rights and does not refer to faulty goods.

R&G

Unit 1, Shelley's Lane, East Worldham, Alton, Hampshire, GU34 3AQ

Tel: +44 (0)1420 89007 Fax: +44 (0)1420 87301 [www.rg-racing.com](http://www.rg-racing.com) Email: [info@rg-racing.com](mailto:info@rg-racing.com)



**NOTICE DE MONTAGE POUR LP0316 SUPPORT DE PLAQUE  
DUCATI MONSTER 950 (PLUS) 2021-**



**CE KIT CONTIENT LES ARTICLES ILLUSTRÉS ET ÉTIQUETES SUR LA PAGE.**

CERTAINES PARTIES PEUVENT ÊTRE PRÉSENTES UNIQUEMENT POUR LA CLARTÉ DES INSTRUCTIONS.

NE PAS PROCÉDER AU MONTAGE TANT QUE VOUS N'ÊTES PAS SÛR QUE TOUTES LES PIÈCES SOIENT PRÉSENTES.

**VEUILLEZ LIRE TOUTES LES INSTRUCTIONS AVANT DE CONTINUER.**

**EN CAS DE DOUTE LORS DU MONTAGE DE NOS PRODUITS, CONSULTEZ UN DE NOS REVENDEURS OU FAITES APPEL À UN TECHNICIEN QUALIFIÉ.**

VEUILLEZ NOTER QUE LA FAÇON DONT LE KIT EST EMBALLÉ NE REPRÉSENTE PAS NECESSAIREMENT LA MANIÈRE DE LE MONTER SUR LA MOTO.

SI DES RONDELLES EN CAOUTCHOUC SONT UTILISÉES POUR MAINTENIR LES COMPOSANTS SUR LES BOULONS, ELLES PEUVENT ÊTRE JETÉES.

**NOTICE DISPONIBLE AU TÉLÉCHARGEMENT SUR :**  
[WWW.RG-RACING.COM](http://WWW.RG-RACING.COM)

R&G

Unit 1, Shelley's Lane, East Worldham, Alton, Hampshire, GU34 3AQ  
Tel: +44 (0)1420 89007 Fax: +44 (0)1420 87301 [www.rg-racing.com](http://www.rg-racing.com) Email: [info@rg-racing.com](mailto:info@rg-racing.com)



<ul style="list-style-type: none"> <li>• Clés Allen 3, 4, 5 &amp; 6mm</li> <li>• Clé à cliquet + douilles 6 &amp; 8mm.           <ul style="list-style-type: none"> <li>• Petit tournevis plat.</li> </ul> </li> </ul>	<p style="text-align: center;"><b><u>VALEURS DE SERRAGE</u></b></p> <p>M4 BOULON = 8Nm</p> <p>M5 BOULON = 12Nm</p> <p>M6 BOULON = 15Nm</p> <p>M8 BOULON = 20Nm</p> <p>M10 BOULON = 40Nm</p> <p>M12 BOULON = 40Nm</p>
--	--

### **LÉGENDE**

ARTICLE No.	DESCRIPTION	QTÉ
ARTICLE 1	TB0316 PARTIE 1 - SUPPORT DE PLAQUE	1
ARTICLE 2	MP0253 - SUPPORT CLIGNOTANT CÔTÉ GAUCHE	1
ARTICLE 3	MP0254 - SUPPORT CLIGNOTANT CÔTÉ DROIT	1
ARTICLE 4	CON0014 - CONNECTEUR DE FEU DE PLAQUE	1
ARTICLE 5	CON0015 - CONNECTEUR DE CLIGNOTANT	2
ARTICLE 6	LA0002 - ASSEMBLAGE FEU DE PLAQUE	1
ARTICLE 7	M5x0.8x10.0 mm VIS	4
ARTICLE 8	M5x0.8 ÉCROUS	4
ARTICLE 9	M5x10mm RONDELLES	4
ARTICLE 10	REFL 3 - RÉFLECTEUR	1
ARTICLE 11	150mm LONGUEUR DE MANCHON THERMO RÉTRACTABLE	3
ARTICLE 12	2.5mm x 100mm COLLIERS DE SERRAGE	6
ARTICLE 13	IWC0002 - CACHE FIL MINI CLIGNOTANT	2
ARTICLE 14	CLIP 1 - CLIPS CÂBLE AUTOCOLLANTS	2
ARTICLE 15	I0071 - ADAPTATEURS DE MINI CLIGNOTANTS	4

R&G

Unit 1, Shelley's Lane, East Worldham, Alton, Hampshire, GU34 3AQ

Tel: +44 (0)1420 89007 Fax: +44 (0)1420 87301 [www.rg-racing.com](http://www.rg-racing.com) Email: [info@rg-racing.com](mailto:info@rg-racing.com)





**SCHÉMA D'ENSEMBLE**

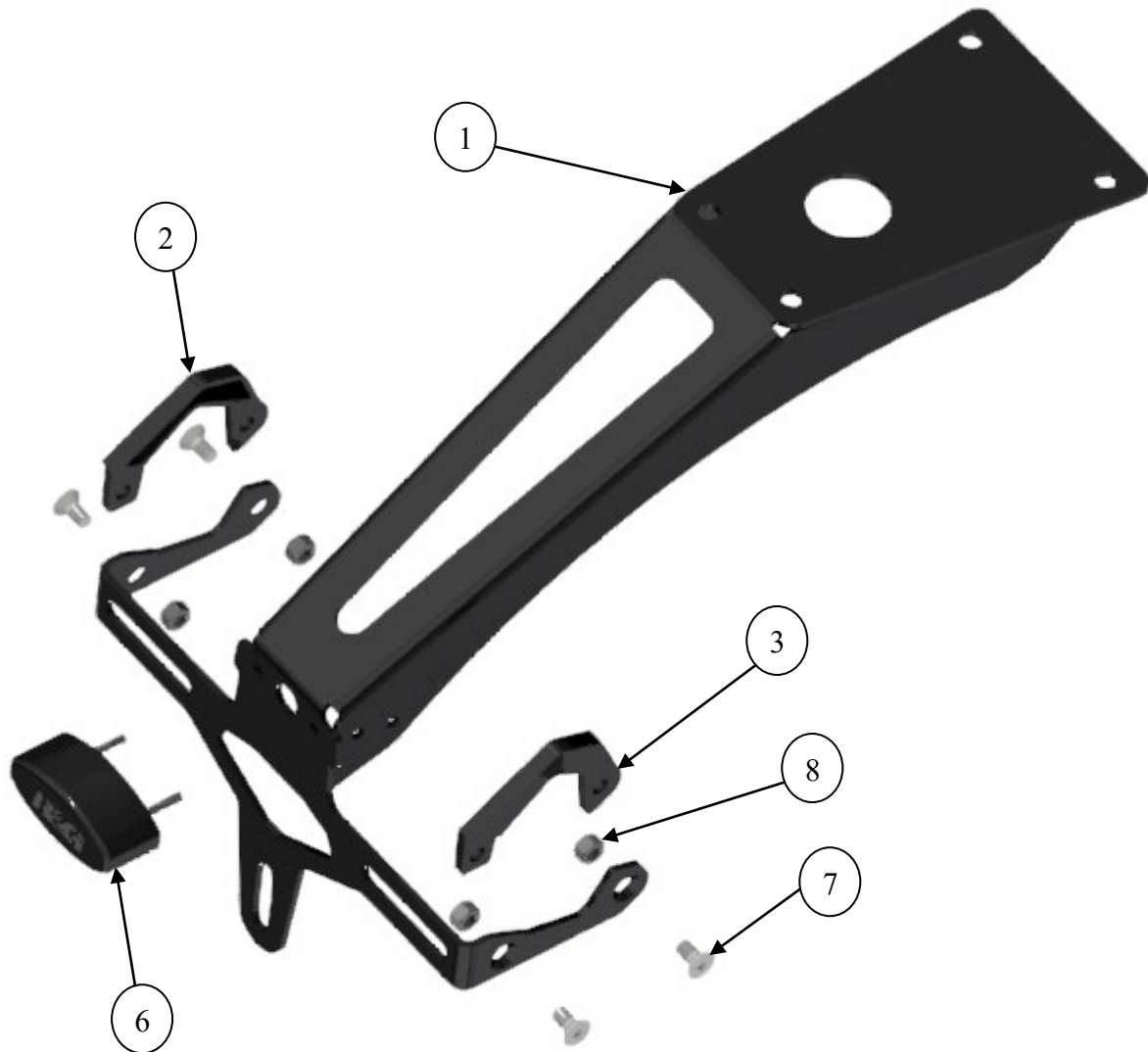



**PHOTOS DE MONTAGE**



Photo 1



Photo 2

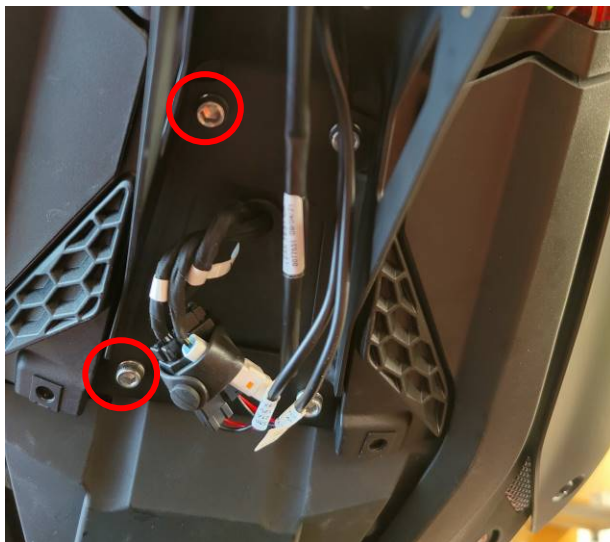

Photo 3



Photo 4

R&G

Unit 1, Shelley's Lane, East Worldham, Alton, Hampshire, GU34 3AQ

Tel: +44 (0)1420 89007 Fax: +44 (0)1420 87301 [www.rg-racing.com](http://www.rg-racing.com) Email: [info@rg-racing.com](mailto:info@rg-racing.com)



Photo 5



Photo 6

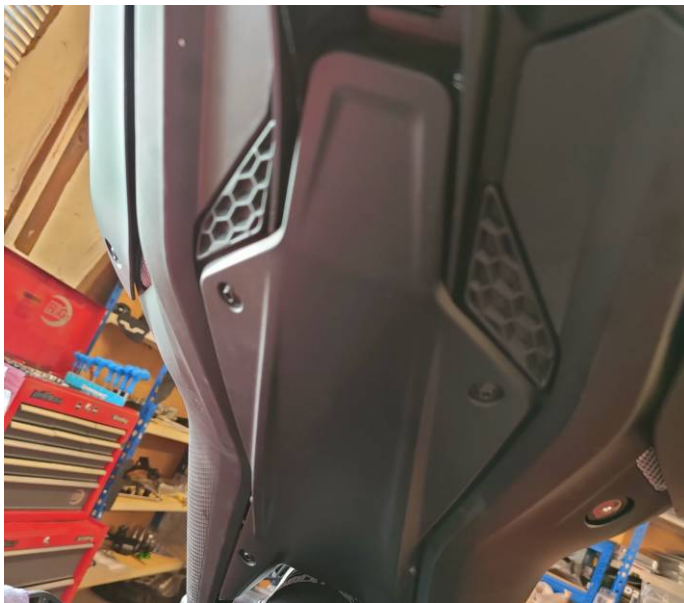

Photo 7



Photo 8

## **NOTICE DE MONTAGE**

- Commencez par retirer les 4 boulons illustrés sur la photo 1 avec une clé Allen de 4 mm.
- Cela vous permet de retirer la plaque de protection en plastique, exposant ainsi les vis de montage du support de plaque d'immatriculation et le câblage.
- Retirez le serre-câble en caoutchouc et débranchez les 3 connecteurs indiqués sur la photo 2.
- Retirez les 4 boulons illustrés sur la photo 3 avec une clé Allen de 5 mm et retirez le support de plaque d'immatriculation d'origine.
- Cela laisse les 3 fils exposés comme indiqué sur la photo 4.
- Si vous réutilisez les clignotants d'origine, placez en sandwich la partie en caoutchouc des clignotants entre le support de plaque d'immatriculation R&G et les supports de clignotants.

R&G

Unit 1, Shelley's Lane, East Worldham, Alton, Hampshire, GU34 3AQ

Tel: +44 (0)1420 89007 Fax: +44 (0)1420 87301 [www.rg-racing.com](http://www.rg-racing.com) Email: [info@rg-racing.com](mailto:info@rg-racing.com)



Celui-ci peut ensuite être fixé avec les attaches M5 fournies. Notez que le caoutchouc peut avoir besoin d'être légèrement comprimé pour permettre aux vis de passer à travers les trous.

- Si vous utilisez des mini clignotants R&G ou d'autres clignotants de rechange, assemblez les plaques de montage comme ci-dessus, sans les clignotants en place. Utilisez ensuite les adaptateurs de clignotants fournis pour fixer les clignotants.
- Fixez l'éclairage de plaque d'immatriculation en position comme indiqué sur la photo 6.
- Montez le support R&G sur la moto, en le fixant avec les mêmes 4 boulons qui ont retiré le support de plaque d'immatriculation d'origine. Assurez-vous de faire passer les fils connectés à la moto, à travers le grand trou au centre du support.
- Reconnectez les clignotants et l'éclairage, en vous assurant que les clignotants gauches et droit soient correctement connectés. Notez qu'il peut être nécessaire d'utiliser les connecteurs fournis pour connecter les connecteurs à clip d'origine.
- Les fils de clignotant et de l'éclairage peuvent être rangés à l'aide des attaches de câble fournies et des petits trous d'attache de câble dans le support.
- La pièce de couverture en plastique illustrée sur la photo 7 peut ensuite être remise en place à l'aide des 4 vis retirées au début du processus. Cette pièce de couverture peut également être utilisée pour cacher le câblage et les connecteurs.
- Le support est alors prêt à fixer votre plaque d'immatriculation comme le montre la photo 8.

**IMPORTANT : SI VOUS INSTALLEZ UNE PLAQUE D'IMMATRICULATION DE GRANDE TAILLE ET LA PLACEZ LOIN VERS LE BAS SUR LE SUPPORT DE PLAQUE D'IMMATRICULATION, IL Y A UNE FAIBLE CHANCE QUE LA PLAQUE D'IMMATRICULATION FRAPPE LA ROUE ARRIÈRE SOUS L'EFFET D'UNE CHARGE LOURDE ET SUR DE GRANDES BOSSES SUR LA ROUTE. IL EST DE VOTRE RESPONSABILITÉ DE VÉRIFIER CETTE POSSIBILITÉ ET DE PRENDRE DES MESURES POUR L'ÉVITER. NE PAS VÉRIFIER CECI POURRAIT ENTRAÎNER DES BLESSURES GRAVES.**

ISSUE 1 - 19/08/2021 - (WW)

#### CONSUMER NOTICE

The catalogue description and any exhibition of samples are only broad indications of the Products and R&G may make design changes which do not diminish their performance or visual appeal and supplying them in such state shall conform to the order. The Buyer acknowledges no representation or warranty (other than as to title) has been given or will apply to the Products other than those in R&G's order or confirmation and the Buyer confirms it has chosen the Products as being of merchantable quality and suitable for its particular purposes. Where R&G fits the Products or undertakes other services it shall exercise reasonable skill and care and rectify any fault free of charge unless the workmanship has been disturbed. The Buyer is responsible for ensuring that the warranty on the motorcycle is not affected by the fitting of the Products. On return of any defective Products R&G shall at its option either supply a replacement or refund the purchase money but shall not be liable if the Products have been modified or used or maintained otherwise than in accordance with R&G's or manufacturer's instructions and good engineering practice or if the defect arises from accident or neglect. Other than identified above and subject to R&G not limiting its liability for causing death and personal injury, it shall not be liable for indirect or consequential loss and otherwise its liability shall be limited to the amounts paid by the Buyer for the Products or the fitting or service concerned. These terms do not affect the Buyer's statutory rights.

#### R&G RACING RETURNS POLICY (NON-FAULTY GOODS)

Returns must be pre-authorized (if not pre-authorized the return will be rejected). Goods may only be returned direct to us if they were purchased direct from us (customer must prove if necessary). Otherwise to be returned to original vendor. Goods must be in re-sellable condition, in the opinion of R&G Racing. All returns are subject to a 25% restocking and handling fee (25% of the gross value exc. P&P – at the prevailing price at time of purchase). The customer must pay any and all carriage charges. No returns of discontinued products, unless within 14 days of purchase. This policy does not affect your statutory rights and does not refer to faulty goods.

R&G

Unit 1, Shelley's Lane, East Worldham, Alton, Hampshire, GU34 3AQ

Tel: +44 (0)1420 89007 Fax: +44 (0)1420 87301 [www.rg-racing.com](http://www.rg-racing.com) Email: [info@rg-racing.com](mailto:info@rg-racing.com)





**MONTAGEANLEITUNG FÜR LP0316 KENNZEICHENHALTER  
DUCATI MONSTER 950 (PLUS) 2021-**



**Alle Kit-Teile sind auf den nachfolgenden Seiten abgebildet und gekennzeichnet.**

**Die abgebildeten Teile dienen lediglich zur Erklärung.**

**Überprüfen Sie zuerst, dass alle Teile vorhanden sind.**

**Lesen Sie die Montageanleitung komplett durch, bevor Sie anfangen**

**WENN SIE BEI DER MONTAGE DIESES PRODUKTES UNSICHER SIND, BITTE EINEN  
UNSERER HÄNDLER KONTAKTIEREN ODER DAS KIT VON EINEM QUALIFIZIERTEN  
ZWEIRAD-MECHANIKER MONTIEREN LASSEN.**

Die Verpackung der Teile stellt nicht die Reihenfolge der Montage dar.

Hinweis für Kits mit Plastikunterlegscheiben an den Schrauben –  
Diese Plastik-Unterlegscheiben werden nicht für den Einbau benötigt.

**EINE DIGITALE VERSION DIESER MONTAGEANLEITUNG KANN AUF FOLGENDER  
SEITE HERUNTERGELADEN WERDEN:  
[WWW.RG-RACING.COM](http://WWW.RG-RACING.COM)**

R&G

Unit 1, Shelley's Lane, East Worldham, Alton, Hampshire, GU34 3AQ  
Tel: +44 (0)1420 89007 Fax: +44 (0)1420 87301 [www.rg-racing.com](http://www.rg-racing.com) Email: [info@rg-racing.com](mailto:info@rg-racing.com)



<b><u>SIE BENÖTIGEN FOLGENDES WERKZEUG</u></b>	<b><u>ALLGEM. ANZUGSDREHMOMENT</u></b>
<ul style="list-style-type: none"> <li>• Satz Inbusschlüssel inkl. 3, 4, 5 &amp; 6mm</li> <li>• 6 &amp; 8mm Schraubenschlüssel oder Steckschlüssel</li> <li>• Kl. Flachklingen-Schraubendreher</li> </ul>	M4 SCHRAUBE = 8Nm M5 SCHRAUBE = 12Nm M6 SCHRAUBE = 15Nm M8 SCHRAUBE = 20Nm M10 SCHRAUBE = 40Nm M12 SCHRAUBE = 40Nm

### **LIEFERUMFANG**

<b>ARTIKEL NR.</b>	<b>BESCHREIBUNG</b>	<b>MENGE</b>
ARTIKEL 1	TB0316 TEIL 1 - KENNZEICHENHALTER	1
ARTIKEL 2	MP0253 - HALTERUNG BLINKER LINKE SEITE	1
ARTIKEL 3	MP0254 - HALTERUNG BLINKER RECHTE SEITE	1
ARTIKEL 4	CON0014 - VERBINDUNG KENNZEICHENBELEUCHTUNG	1
ARTIKEL 5	CON0015 - VERBINDUNG BLINKER	2
ARTIKEL 6	LA0002 - KENNZEICHENBELEUCHTUNG	1
ARTIKEL 7	M5x0.8x10.0 mm SENKSCHRAUBE	4
ARTIKEL 8	M5x0.8 SELBSTSICHERNDE MUTTER	4
ARTIKEL 9	M5x10mm UNTERLEGSCHIEBE	4
ARTIKEL 10	REFL 3 - RÜCKSTRAHLER	1
ARTIKEL 11	150mm SCHRUMPFSCHLAUCH	3
ARTIKEL 12	2.5mm x 100mm KABELBINDER	6
ARTIKEL 13	IWC0002 - MINIBLINKER KABEL-ABDECKUNG	2
ARTIKEL 14	CLIP 1 - SELBSTKLEBENDE KABELCLIPS	2
ARTIKEL 15	I0071 - ADAPTER FÜR MINIBLINKER	4

R&amp;G

Unit 1, Shelley's Lane, East Worldham, Alton, Hampshire, GU34 3AQ

Tel: +44 (0)1420 89007 Fax: +44 (0)1420 87301 [www.rg-racing.com](http://www.rg-racing.com) Email: [info@rg-racing.com](mailto:info@rg-racing.com)



**ZEICHNUNG - ZUSAMMENBAU**

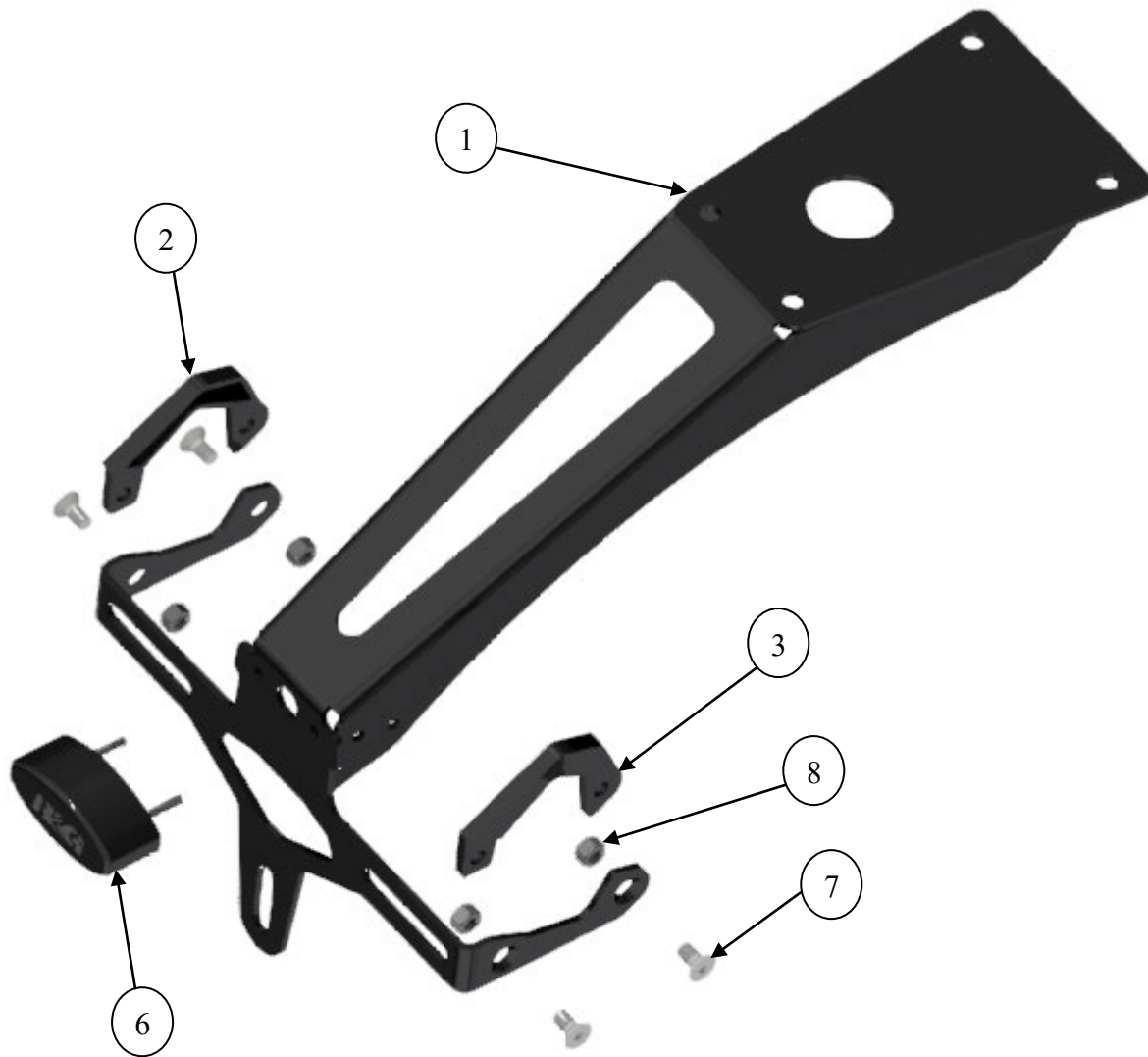

R&G

Unit 1, Shelley's Lane, East Worldham, Alton, Hampshire, GU34 3AQ

Tel: +44 (0)1420 89007 Fax: +44 (0)1420 87301 [www.rg-racing.com](http://www.rg-racing.com) Email: [info@rg-racing.com](mailto:info@rg-racing.com)





**MONTAGE - ABBILDUNGEN**



Abbildung 1



Abbildung 2



Abbildung 3



Abbildung 4

R&G

Unit 1, Shelley's Lane, East Worldham, Alton, Hampshire, GU34 3AQ

Tel: +44 (0)1420 89007 Fax: +44 (0)1420 87301 [www.rg-racing.com](http://www.rg-racing.com) Email: [info@rg-racing.com](mailto:info@rg-racing.com)



Abbildung 5



Abbildung 6



Abbildung 7



Abbildung 8

## **MONTAGEANLEITUNG**

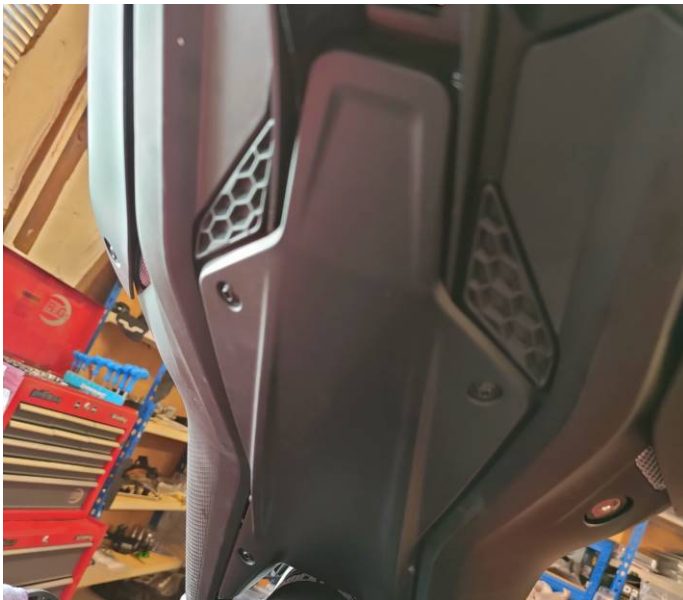
- Fangen Sie an, indem Sie die 4 Schrauben, die in **Abbildung 1** abgebildet sind mit einem 4mm Inbusschlüssel entfernen.
- Danach können Sie die Kunststoff-Abdeckplatte entfernen, um an die Schrauben und die Verkabelung des Kennzeichenhalter zu gelangen.
- Entfernen Sie den Kunststoff-Kabelbinder und trennen Sie die drei Verbindungen, die in **Abbildung 2** abgebildet sind.
- Entfernen Sie die 4 Schrauben, die in **Abbildung 3** abgebildet sind mit einem 5mm Inbusschlüssel und entfernen Sie den original Kennzeichenhalter.
- Danach liegen die 3 Kabel offen wie in **Abbildung 4** abgebildet.
- Wenn Sie die Originalblinker wieder montieren, das Gummiteil an den Blinkern zwischen dem R&G Kennzeichenhalter und den Blinker-Halterungen einklemmen. Dies kann dann mit den M5

R&G

Unit 1, Shelley's Lane, East Worldham, Alton, Hampshire, GU34 3AQ

Tel: +44 (0)1420 89007 Fax: +44 (0)1420 87301 [www.rg-racing.com](http://www.rg-racing.com) Email: [info@rg-racing.com](mailto:info@rg-racing.com)



Befestigungen gesichert werden. Eventuell muss das Gummi zusammengedrückt werden, sodass die Schrauben durch die Öffnungen passen.

- Wenn Sie die R&G Miniblinker oder Blinker aus dem Zubehörmarkt montieren, die Montageplatte wie oben zusammen bauen ohne die Distanzhalter. Dann die Blinker-Adapter fixieren, um die Blinker zu sichern.
- Die Kennzeichenbeleuchtung in Position befestigen wie in **Abbildung 6** abgebildet.
- Den R&G Kennzeichenhalter am Motorrad fixieren und mit denselben 4 Schrauben sichern, die vom original Kennzeichenhalter entfernt wurden. Achten Sie darauf, dass die Kabel, die mit dem Motorrad verbunden sind durch die große Öffnung im Kennzeichenhalter geführt werden.
- Verbinden Sie die Blinker und Kennzeichenbeleuchtung wieder und stellen Sie sicher, dass die Blinker für die rechte und linke Seite entsprechend angeschlossen sind. Hinweis: die Verbindungen vom Kit müssen eventuell benutzt werden, um die Kabelverbindungen mit den original Steckverbindungen zu verbinden.
- Die Kabel für die Blinker und die Kennzeichenbeleuchtung können mit den mitgelieferten Kabelbindern ordentlich fixiert werden (an den kleinen Öffnungen im Kennzeichenhalter für die Kabelbinder).
- Die Abdeckverkleidung aus Plastik, die in **Abbildung 7** abgebildet ist, kann dann wieder montiert werden mit den 4 Schrauben, die am Anfang entfernt wurden. Die Abdeckverkleidung kann auch benutzt werden, um die Kabel und Verbindungen zu verstecken.
- Montieren Sie nun das amtliche Kennzeichen wie in **Abbildung 8** abgebildet.

**WICHTIG: WENN EIN GROSSES KENNZEICHEN ZU WEIT NACH UNTEN MONTIERT WIRD, BESTEHT BEI SCHWERER LAST ODER DURCH GROSSE BODENWELLEN EIN GERINGES RISIKO, DASS DAS KENNZEICHEN AN DAS HINTERRAD STOSSEN KANN. ES LIEGT IN IHRER VERANTWORTUNG DIES ZU ÜBERPRÜFEN UND, WENN NOTWENDIG, VORZUBEUGENDE MASSNAHMEN ZU ERGREIFEN. DIE NICHTBEACHTUNG DIESER SICHERHEITSHINWEIS KANN ZU SCHWEREN VERLETZUNGEN FÜHREN.**

AUSGABE 1 - 19/08/2021 - (WW)

#### CONSUMER NOTICE

The catalogue description and any exhibition of samples are only broad indications of the Products and R&G may make design changes which do not diminish their performance or visual appeal and supplying them in such state shall conform to the order. The Buyer acknowledges no representation or warranty (other than as to title) has been given or will apply to the Products other than those in R&G's order or confirmation and the Buyer confirms it has chosen the Products as being of merchantable quality and suitable for its particular purposes. Where R&G fits the Products or undertakes other services it shall exercise reasonable skill and care and rectify any fault free of charge unless the workmanship has been disturbed. The Buyer is responsible for ensuring that the warranty on the motorcycle is not affected by the fitting of the Products. On return of any defective Products R&G shall at its option either supply a replacement or refund the purchase money but shall not be liable if the Products have been modified or used or maintained otherwise than in accordance with R&G's or manufacturer's instructions and good engineering practice or if the defect arises from accident or neglect. Other than identified above and subject to R&G not limiting its liability for causing death and personal injury, it shall not be liable for indirect or consequential loss and otherwise its liability shall be limited to the amounts paid by the Buyer for the Products or the fitting or service concerned. These terms do not affect the Buyer's statutory rights.

#### R&G RACING RETURNS POLICY (NON-FAULTY GOODS)

Returns must be pre-authorized (if not pre-authorized the return will be rejected). Goods may only be returned direct to us if they were purchased direct from us (customer must prove if necessary). Otherwise to be returned to original vendor. Goods must be in re-sellable condition, in the opinion of R&G Racing. All returns are subject to a 25% restocking and handling fee (25% of the gross value exc. P&P – at the prevailing price at time of purchase). The customer must pay any and all carriage charges. No returns of discontinued products, unless within 14 days of purchase. This policy does not affect your statutory rights and does not refer to faulty goods.

R&G

Unit 1, Shelley's Lane, East Worldham, Alton, Hampshire, GU34 3AQ

Tel: +44 (0)1420 89007 Fax: +44 (0)1420 87301 [www.rg-racing.com](http://www.rg-racing.com) Email: [info@rg-racing.com](mailto:info@rg-racing.com)